

Design and installation guideline

TOX®-Powerpackage line-X

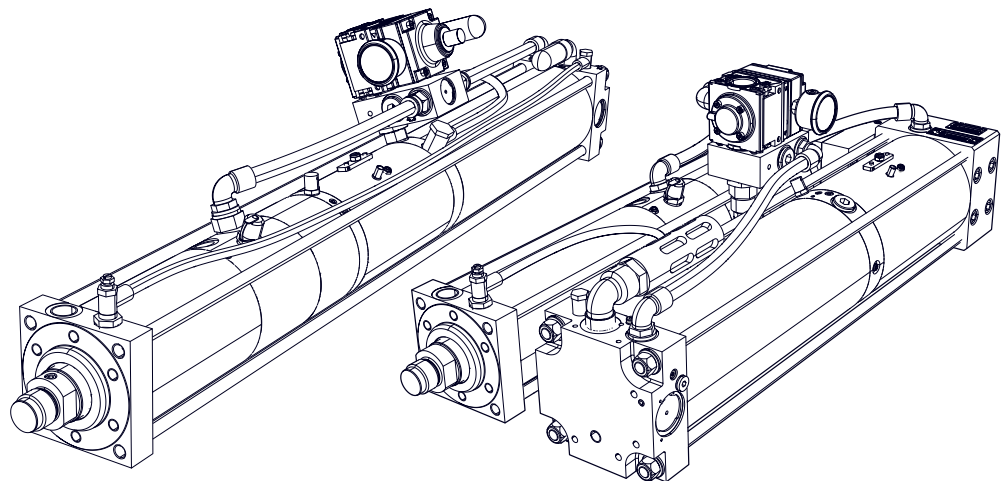

Table of contents

1	Important information	
1.1	Legal note	7
1.2	Exclusion of liability	7
1.3	Validity of the document	8
1.3.1	Content and target group	8
1.3.2	Other applicable documents	8
1.3.3	Contact and source of supply	8
1.4	Gender note	8
1.5	Contact and source of supply	9
2	Product overview of Powerpackage line-X	
2.1	Product attributes of Powerpackage line-X	11
3	Optional equipment	
3.1	Product overview of Powerpackage with integrated damping function	13
3.1.1	Product attributes of Powerpackage with integrated damping function ZED	14
3.2	Product overview of Powerpackage with integrated holding brake	14
3.2.1	Product attributes of Powerpackage with integrated holding brake ZSL... ..	14
3.3	Additional optional equipment	15
4	Function description of Powerpackage with pressure regulator pneumatic spring	
5	Technical data	
5.1	Type sheet and data sheet	21
5.2	Compressed air quality and pneumatic connection	21
5.2.1	Pneumatic connection, air pressure, oil pressure	21
5.3	Tightening torques	22
5.3.1	Tightening torques for flange mounting the drive	22
5.3.2	Tightening torques on the piston rod	22

5.4	Press force table	22
5.5	Specification for hydraulic oil.....	23
6	Design data	
6.1	Data sheet.....	25
7	Design guidelines	
7.1	Design principles	27
7.1.1	Air consumption	28
7.1.2	Cycle times.....	29
7.2	Performance optimization	30
7.3	Avoidance of dynamic oil leakage.....	30
7.3.1	Setting speed ratio of return stroke to fast approach stroke	31
7.3.2	Set the speed ratio between power stroke and power stroke venting (optional)	31
7.4	Stroke limitation of the power stroke	32
7.5	Power limit of the power stroke	33
7.6	Speed reduction of the power stroke	33
7.7	Changeover of power stroke to return stroke for Powerpackages with hydraulic damping (ZED, ZSD)	33
7.8	Horizontal installation Type K and Z	33
7.9	Holding brake (Assembly ZSL)	34
7.9.1	Electrical activation	34
8	Activation and pressure control	
8.1	Design principles of activation.....	35
8.1.1	Measuring connection and control connection.....	36
8.2	Activation according to dynamic pressure method for Powerpackage.....	37
8.2.1	Powerpackage with pressure valve (pneumatic spring).....	38
8.3	Pressure control in the power stroke line (assembly ZDK) (optional)	42
8.3.1	Powerpackage with pressure valve (pneumatic spring).....	42
8.4	Pressure control in the power stroke line with proportional pressure control valve (optional).....	44
8.4.1	Powerpackage with pressure valve (pneumatic spring).....	44

8.5	External power stroke switch (assembly ZKHZ) (optional)	46
8.5.1	Powerpackage with pressure valve (pneumatic spring)	47
8.6	External power stroke deactivation (assembly ZKHD) (optional)	49
8.6.1	Powerpackage with pressure valve (pneumatic spring)	49
8.7	External power stroke release (assembly ZKHF) (optional)	51
8.7.1	Powerpackage with pressure valve (pneumatic spring)	51
8.8	External power stroke supply (optional)	53
8.8.1	Powerpackage with pressure valve (pneumatic spring)	54
8.9	Adjustable damping (assembly ZED) (optional)	56

Index

1 Important information

1.1 Legal note

All rights reserved.

Operating instructions, manuals, technical descriptions and software published by TOX® PRESSOTECHNIK GmbH & Co. KG ("TOX® PRESSOTECHNIK") are copyright and must not be reproduced, distributed and/or otherwise processed or edited (e.g. by copying, microfilming, translation, transmission in any electronic medium or machine-readable form). Any use - including of extracts - contrary to this condition is prohibited without approval in writing by TOX® PRESSOTECHNIK and may be subject to criminal and civil legal sanctions.

If this manual refers to goods and/or services of third parties, this is for example only or is a recommendation by TOX® PRESSOTECHNIK.

TOX® PRESSOTECHNIK does not accept any liability or warranty/guarantee with reference to the selection, specifications and/or usability of these goods and services. The use and/or representation of trademarked brands that do not belong to TOX® PRESSOTECHNIK are for information only; all rights remain the property of the owner of the trademarked brand.

Operating instructions, manuals, technical descriptions and software are originally compiled in German.

1.2 Exclusion of liability

TOX® PRESSOTECHNIK has checked the contents of this publication to ensure that it conforms to the technical properties and specifications of the products or plant and the description of the software. However, discrepancies may still be present, so we cannot guarantee complete accuracy. The supplier documentation included with the system documentation is an exception.

However, the information in this publication is checked regularly and any required corrections are included in subsequent editions. We are grateful for any corrections and suggestions for improvement. TOX® PRESSOTECHNIK reserves the right to revise the technical specifications of the products or plant and/or the software or documentation without prior notice.

1.3 Validity of the document

1.3.1 Content and target group

This design and installation guideline contains information and instructions for the design and installation of the product.

- All information in this design and installation guideline is up to date at the time of print. TOX® PRESSOTECHNIK reserves the right to make technical changes that improve the system or increase the standard of safety.
- The information is intended for the designer and operating company.

1.3.2 Other applicable documents

The following documents must also be observed in addition to the design and installation guideline:

- Data sheet TOX®-Powerpackage
- Data sheet TOX®-Powerpackage Control units
- Data sheet TOX®-Powerpackage Accessories
- Any supplier documentation

See <http://www.tox-pressotechnik.de>.

1.3.3 Contact and source of supply

Please send any questions on the technical documentation (e.g. missing documents, suggestions, corrections) by email to info@tox-de.com.

1.4 Gender note

In order to enhance readability, references to persons that also relate to all sexes are normally only stated in the usual form in German or in the corresponding translated language in this manual, thus e.g. "operator" (singular) for male or female, or "operators" (plural) for male or female". This should in no way convey any gender discrimination or any violation of the principle of equality, however.

1.5 Contact and source of supply

Only use original spare parts or spare parts approved by TOX® PRESSOTECHNIK.

TOX® PRESSOTECHNIK GmbH & Co. KG

Riedstraße 4

D - 88250 Weingarten

Tel. +49 (0) 751/5007-333

E-Mail: info@tox-de.com

For additional information and forms see www.tox-pressotechnik.com.

2 Product overview of Powerpackage line-X

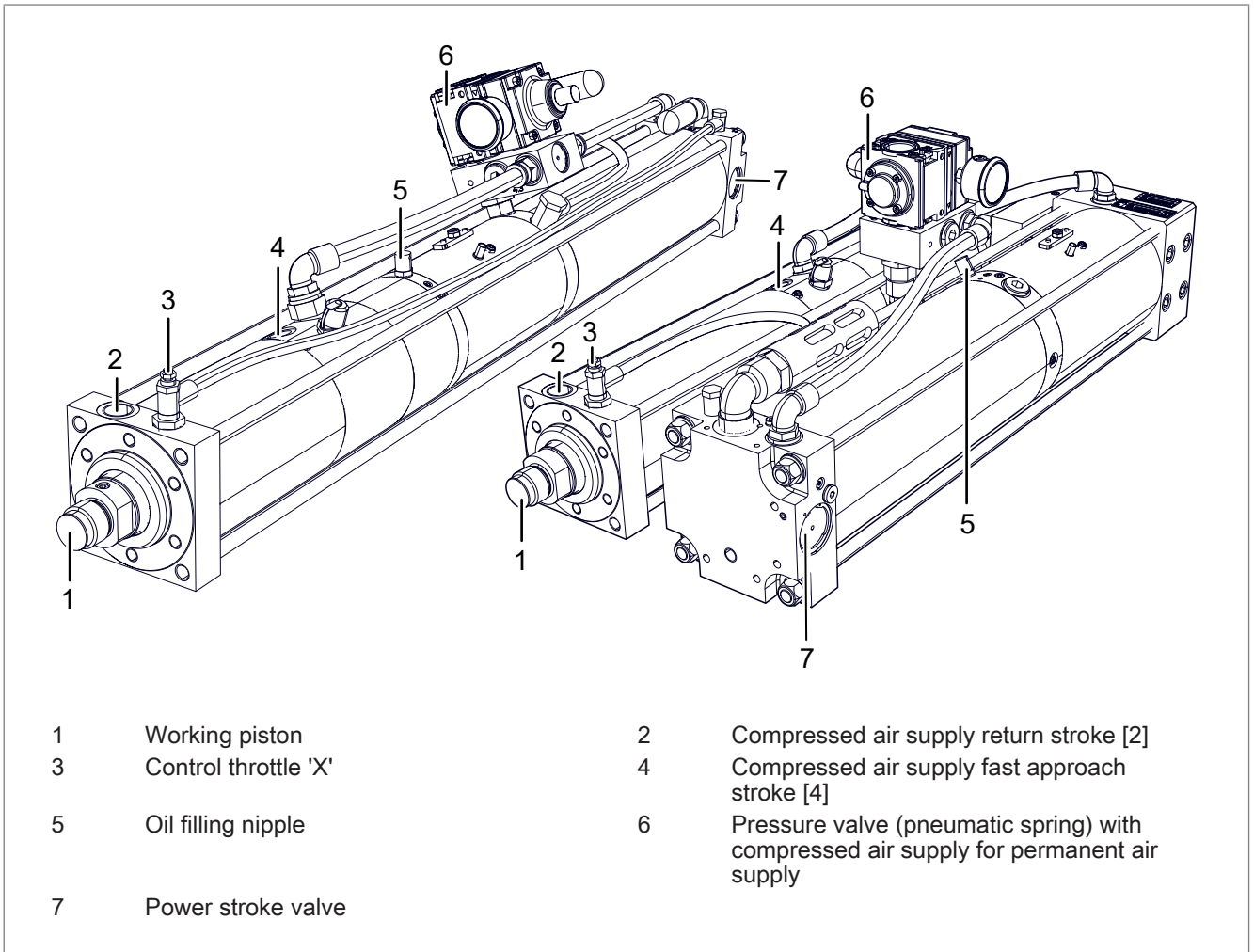

Fig. 1 Product overview type X-S, X-K

2.1 Product attributes of Powerpackage line-X

Type X-S	Type X-K
<ul style="list-style-type: none"> Intensifier and working part are interconnected with a tension rod in a sandwich construction. 	<ul style="list-style-type: none"> Intensifier and working part are connected with an intermediate flange (compact construction).
<ul style="list-style-type: none"> Including power stroke valve and control throttle 'X'. 	
<ul style="list-style-type: none"> Including pressure valve (pneumatic spring) and fast stroke support. 	
<ul style="list-style-type: none"> Including fixed stop with elastomer cushioning in the lower final position. 	
<ul style="list-style-type: none"> Including power bypass ZLB with hydraulic end position cushioning ZHD in the upper final position. 	
<ul style="list-style-type: none"> Prepared for stroke monitoring ZHU (up to and including X-S 30/X-K 30). 	
<ul style="list-style-type: none"> Prepared for external linear position sensor ZHW (up to and including X-S 30/X-K 30). 	

3 Optional equipment

3.1 Product overview of Powerpackage with integrated damping function

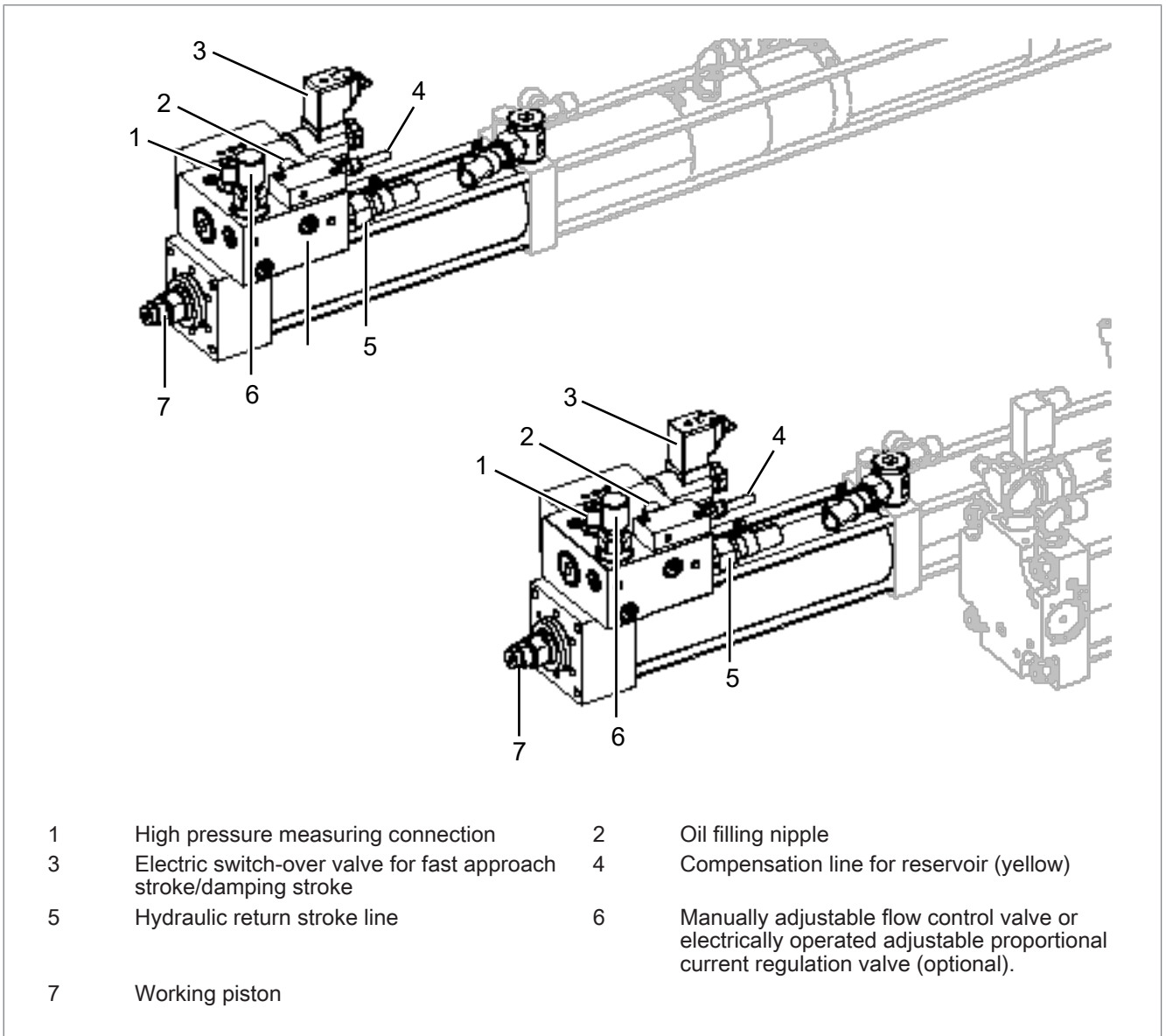

Fig. 2 Product overview of Powerpackage with integrated damping function

3.1.1 Product attributes of Powerpackage with integrated damping function ZED

Type X-SD	Type X-KD
<ul style="list-style-type: none"> Intensifier and working part are interconnected with a tension rod (sandwich construction) 	<ul style="list-style-type: none"> Intensifier and working part are connected with an intermediate flange (compact construction).
<ul style="list-style-type: none"> With integrated damping function. Allows a selectable constant speed of the working piston during the approach stroke and power stroke, independent of the respective working forces. Manually adjustable flow control valve or optional electrically operated adjustable proportional current regulation valve. 	
<ul style="list-style-type: none"> The oil pressure cannot be used as signal for the return stroke. To switch over from power stroke to return stroke, a distance-dependent signal must be selected. 	
<ul style="list-style-type: none"> With power bypass ZLB including hydraulic end position cushioning ZHD in the upper final position. 	
<ul style="list-style-type: none"> Equipped with pressure valve (pneumatic spring) and fast stroke support. 	
<ul style="list-style-type: none"> Prepared for stroke monitoring ZHU (up to X-SD 30, EL 30). 	
<ul style="list-style-type: none"> Prepared for external linear position sensor ZHW (up to X-SD 30, EL 30). 	
<ul style="list-style-type: none"> Including external power stroke connection (ZKHZ). 	

3.2 Product overview of Powerpackage with integrated holding brake

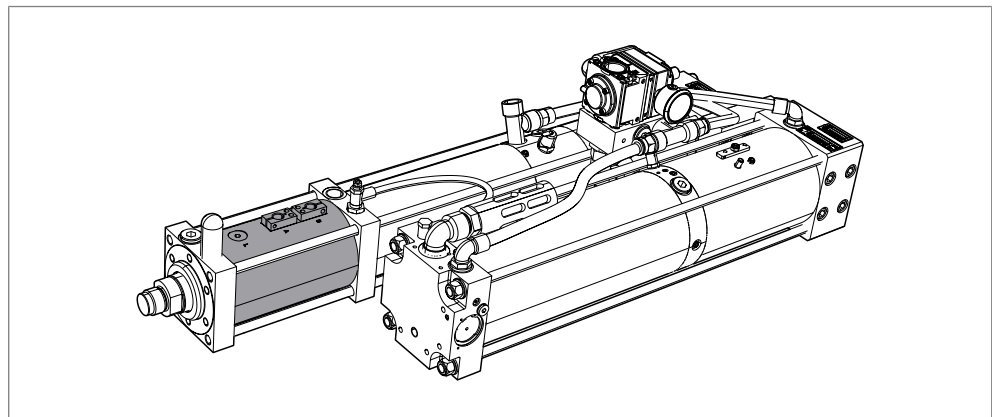

Fig. 3 Product overview of Powerpackage with integrated holding brake ZSL

3.2.1 Product attributes of Powerpackage with integrated holding brake ZSL

Integrated holding brake ZSL

- Integrated holding brake (Safety Lock) (for almost all series)
The holding brake is held open pneumatically and responds at a drop in pressure. The energy of the crashing or dropping load is used for generating the clamping force.

3.3 Additional optional equipment

Type	Product attributes
ZKW	Linear position sensor <ul style="list-style-type: none"> The travel sensor indicates the absolute actual position of the piston. For internal installation (for series K and EK).
ZHW	Linear position sensor <ul style="list-style-type: none"> The travel sensor indicates the absolute actual position of the piston. For external installation (for series line-Q and line-X to Q-S/Q-K 30, X-SX-K 30).
ZHU	Stroke monitoring <ul style="list-style-type: none"> Determines the position of the working piston during forward stroke and return stroke via the external sensor.
ZDK	Pressure regulation in power stroke line <ul style="list-style-type: none"> Make possible the individual adjustment of the press force with a manual pressure valve or electrical proportional valve.
ZKHZ	External power stroke connection <ul style="list-style-type: none"> Enables the connection of the power stroke valve with an electrically actuated 3/2-way valve.
ZWK	Tool coupling <ul style="list-style-type: none"> Connects the drive and tool flexibly to prevent transverse forces from affecting the drive.
ZDO	Electronic pressure switch <ul style="list-style-type: none"> Records the oil pressure in the high-pressure part as system pressure and visualizes it via a four-digit LED display. The set switching function allows 2 output signals to be created.
ZHO	Stroke frequency optimization <ul style="list-style-type: none"> Reduces the cycle time. Replaces the existing power stroke valve with one of the next size.
ZPS	Pressing force sensor <ul style="list-style-type: none"> Measures the press forces in the direction of the pressure.

Tab. 1 Optional equipment

For optional equipment, see data sheet and brochure TOX®-Powerpackage.

<http://tox-pressotechnik.com/>

4 Function description of Powerpackage with pressure regulator pneumatic spring

The drive works with a pneumatically operated cylinder with pneumohydraulic power stroke. At the same time, a closed oil cylinder and valve system is driven with compressed air, which is controlled in the same way as a double-acting pneumatic cylinder.

Compressed air is converted to oil pressure in the intensifier part to generate the necessary pressure for the power stroke. In the working part, the oil pressure acts on the working piston.

The compressed air is also used for the fast approach of the working piston to the working position (fast approach stroke) and for the return to the home position (return stroke).

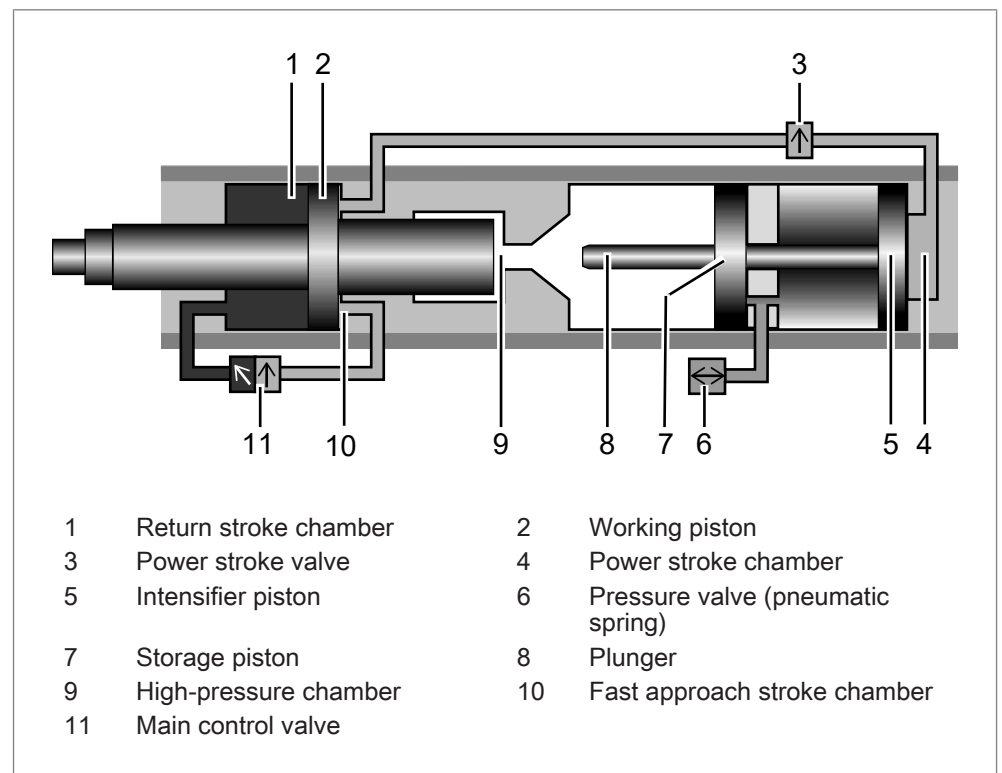

Fig. 4 Starting position of Powerpackage with pressure regulator pneumatic spring

- In home position, the drive is controlled via the main control valve in the return stroke.
- The working piston is retracted.

Pneumatically operated fast approach stroke

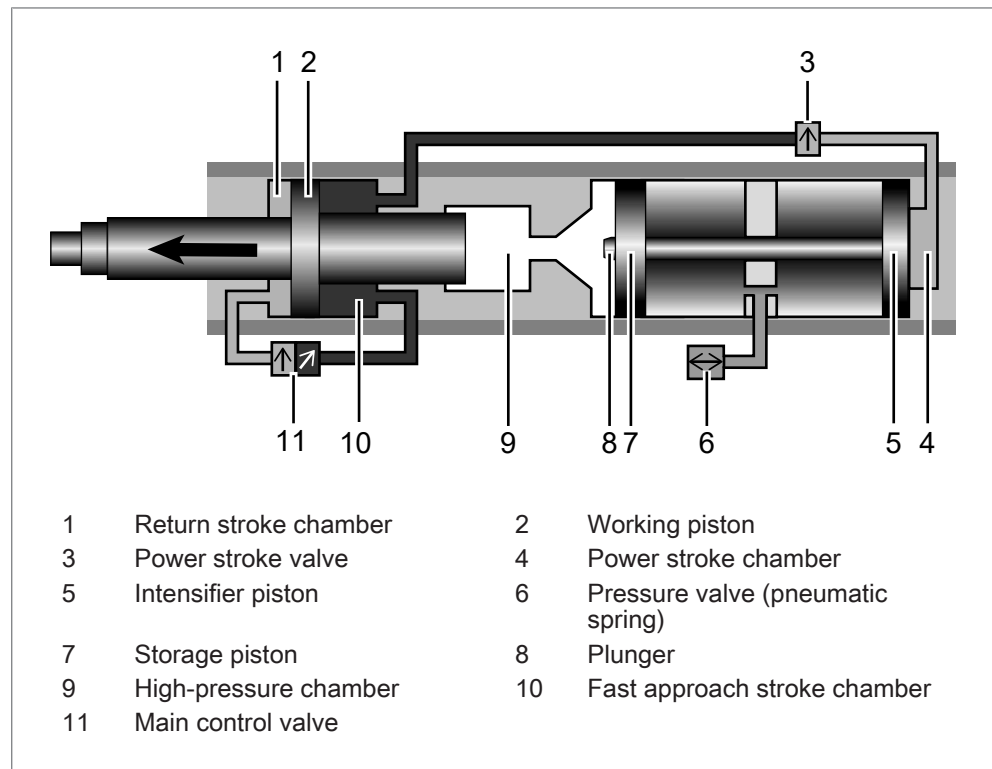

Fig. 5 Fast approach stroke Powerpackage with pressure regulator pneumatic spring

- After switching over the main control valve to forward stroke, compressed air enters the fast approach stroke chamber. The return stroke chamber is being vented.
- The power stroke valve is supplied with compressed air.
- The working piston extends with a fast approach stroke.
- The feed piston pushes hydraulic oil from the reservoir into the high pressure chamber activated by the pressure valve (pneumatic spring).
- As soon as the working piston meets any resistance, it stops.
- The power stroke valve switches over independently to power stroke after a delay, depending on the air volume flowing out of the control throttle 'X'.

Pneumohydraulic power stroke

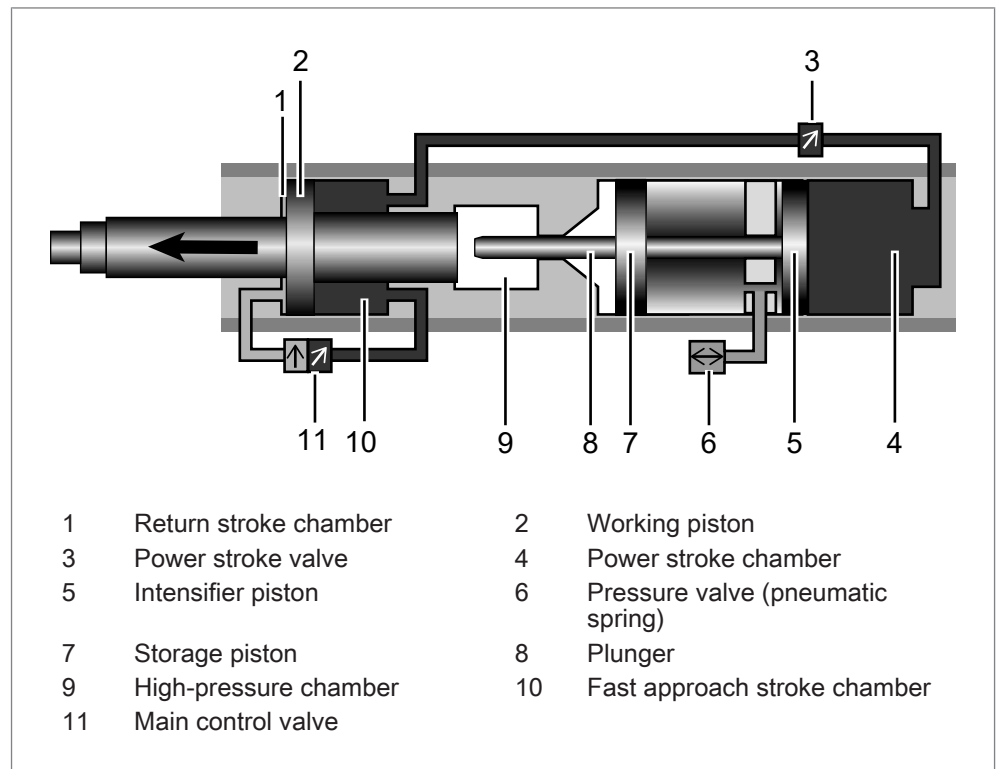

Fig. 6 Power stroke Powerpackage with pressure regulator pneumatic spring

- Compressed air from the forward stroke connection penetrates into the power stroke chamber of the intensifier piston via a connection line.
- The plunger passes through the high pressure seal and separates the oil chamber into a working area and an oil reservoir.
- A hydraulic pressure is generated in working area, which creates the power stroke via the working piston.

Back stroke

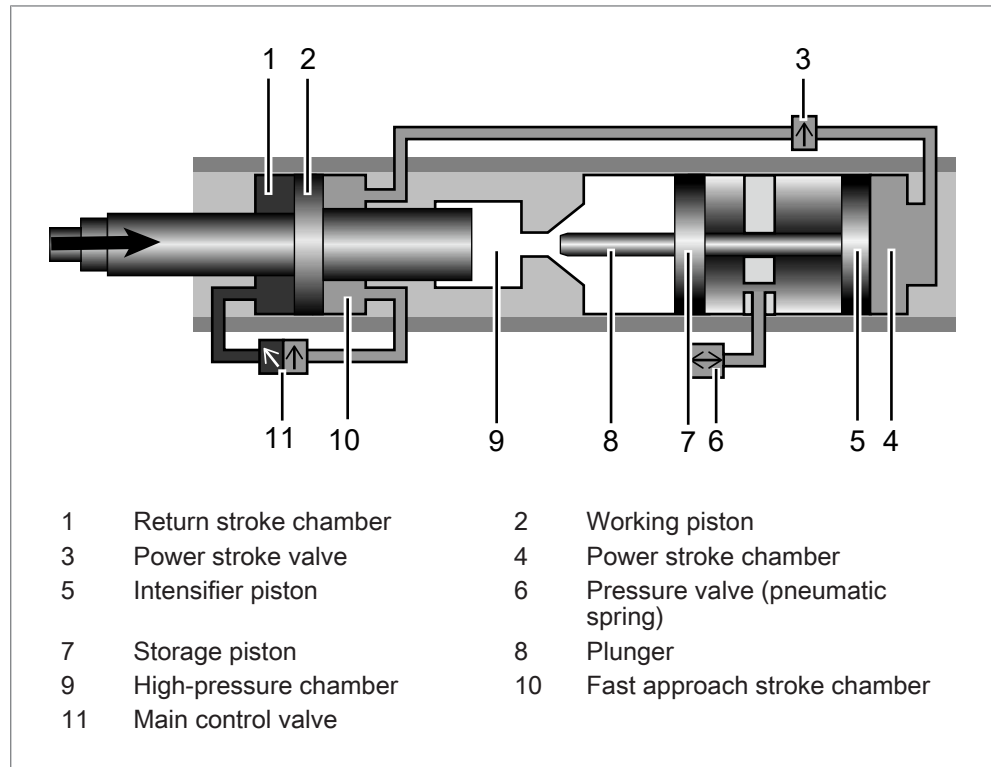

Fig. 7 Return stroke Powerpackage with pressure regulator pneumatic spring

- The main control valve is switched over to return stroke by a signal. The return stroke chamber is being filled with compressed air.
- As a result, the power stroke valve is vented and moved to the home position.
- The power stroke chamber of the intensifier piston is vented via the muffler and the return stroke is triggered.
- After the intensifier piston has released the high pressure seal, the working piston moves back to the home position.

5 Technical data

5.1 Type sheet and data sheet

For technical data and installation dimensions see type sheet and data.
(<https://www.tox-pressotechnik.com>)

5.2 Compressed air quality and pneumatic connection

The following is required:

- Filtered and dried compressed air

Lightly oiled compressed air is permitted.

Compressed air quality (according to DIN ISO 8573-1):

Solids		Water dew point		Maximum Oil content	
Class	[μm]	Class	[$^{\circ}\text{C}$]	Class	[mg/m^3]
5	40	4	3	3	1

5.2.1 Pneumatic connection, air pressure, oil pressure

See data sheet.

(<http://www.tox-pressotechnik.de>).

Separate compressed air supply for the permanent air supply of pressure valve (pneumatic spring):

- Default setting: P_{EL} 0.8 bar
- Minimum supply pressure of pressure valve: $P_{\text{min}} = 2.5$ bar.

5.3 Tightening torques

5.3.1 Tightening torques for flange mounting the drive

Thread size	Torque
M 6	17 Nm
M 8	40 Nm
M 10	80 Nm
M 16	340 Nm
M 20	660 Nm
M 24	1,130 Nm

5.3.2 Tightening torques on the piston rod

Tool coupling ZWK	Tightening torque
ZWK 001	10 Nm
ZWK 002	15 Nm
ZWK 004	40 Nm
ZWK 008	180 Nm
ZWK 015	210 Nm
ZWK 030	230 Nm
ZWK 050	290 Nm
ZWK 075	500 Nm
ZWK 200	500 Nm

5.4 Press force table

The effective press force is the ratio of the available press force at the specified air pressure to the press force required for the pressing process.

Press force table see separate document.

5.5 Specification for hydraulic oil

The following oils are approved for standard application:

- Hydraulic oil HLP32 (according to DIN 51524-2), filtered < 5µm, load rating > 30 N/mm²
- Food grade oil Klüber Summit HySyn FG 32

The following hydraulic oils are approved with limitations for standard application:

- Hydraulic oil UCON™ LB-165
- Synthetic oil ISOTEX 46
- Synthetic oil Envolubric PC 46 NWL
- The use of hydraulic oils that have not been approved as standard can lead to an increase of maintenance intervals due to an increased intake of air.
- The use of hydraulic oils that have not been approved as standard can reduce the lubrication capacity lower than for HLP32 hydraulic oils. This can lead to a shorter lifetime of seals.
- Some sealing materials in case of hydraulic oils not approved as standard tend towards increased swelling and therefore to a reduced lifetime of the seals.

NOTE

Loss of warranty in case of the use of non-approved hydraulic oils!

Due to the negative effects on maintenance intervals, swelling behavior and lifetime of the seals in case of the use of hydraulic oils that have not been approved as standard, the granted warranty becomes extinct.

- Use hydraulic oils that have been approved by TOX® PRESSOTECHNIK as standard.
- Use other hydraulic oils only after the express approval of TOX® PRESSOTECHNIK.
- Do not mix different hydraulic oils. Negative effects such as flocculation cannot be excluded.

6 Design data

6.1 Data sheet

For technical data and installation dimensions see data sheet.
(<http://www.tox-pressotechnik.de>)

7 Design guidelines

7.1 Design principles

- When fastening, note the following:
 - Installation dimensions
 - Weight, including weight of the accessories
 - Press force
 - Loads caused by the working process (dynamics and vibrations)
- No transverse forces may act on the piston rod.
If necessary, use a linear guide for the working piston: either a ram plate and guiding columns or a guiding rail with guiding carriage.
- In the case of horizontal installation the connection side must face upwards.
- Elements requiring servicing maintenance, such as oil filling nipple, vent hole, high pressure measuring connection, control throttle, 'X' and oil level indicator should be accessible.
- Make sure that the ventilation of the hydraulic system is always possible even when installed.
- The space requirement for supply lines must be taken into consideration.
- The length of the hose lines, the connection of an oil pressure switch or oil pressure monitor can significantly reduce the power stroke.

7.1.1 Air consumption

- For the air consumption, the fast and return stroke are calculated with the available air pressure.
- The air requirement in the power stroke is calculated depending on the required press force.
For example, this depends on when the required oil pressure is reached.
- If the intensifier chamber is filled with complete air pressure, the air consumption can indeed be higher than the requirement that is actually needed and calculated.

In general, the specification for the air requirement includes all filling processes required for a stroke. The information only refers to the specific drive.

For hoses and valves - in particular for long hoses with large cross sections - which are filled and ventilated together with the drive, their consumption must also be considered when selecting a compressor.

The following applies here: Short lines from the valve to the drive mean economical energy.

When using pressure regulators (e.g. for the pneumatic spring), low internal air consumption cannot be avoided. This is usually in the range of a few liters per hour. Similarly, there might be air losses in the hose and valve connections. In order to avoid air losses, e.g. at night, the drive can be de-pressurized during this time.

7.1.2 Cycle times

The cycle time is calculated depending on the required press force. The following applies:

- The smaller the effective press force, the shorter the cycle time.
- An effective press force over 90 % should be avoided.
- The switching times of the valves and controls upstream of the drive must be taken into consideration for the specified cycle times.

Requirement for achieving the calculated times:

- **Air pressure**

The required air pressure is the result of the desired effective press force. To achieve a short cycle time, an air pressure as high as possible is recommended for fast and return stroke. If the maximum press force of the cylinder is to be reduced, this can be realized with a pressure control ZDK (manual or electric) in the power stroke line.

- **Cross-section of hose**

The line cross sections must at least match the connection sizes provided in order to achieve the calculated cycle time. This applies also to the regulation valves and maintenance units installed upstream of the drive.

Reduced line cross sections can considerably reduce the cycle time.

- **Tube lengths**

The length of the hoses should be kept to a minimum, since the air consumption as well as the cycle time are increased with the length.

- **Compressor performance**

The compressor performance should always be sized with sufficient safety.

- **Speed setting**

The speed can be regulated as required by installing throttle check valves in the fast approach stroke and return stroke lines (except for type RP, T). Furthermore, the speed of the power stroke can be adjusted by mounting a throttle in the power stroke line of the unit. The drive can thus also be used for special applications, such as pressing in bushes, projecting etc.

- **Optimization of stroke frequency ZHO**

The cycle time specifications correspond in general only to the entire drive under realistic conditions. If necessary, the cycle time can be further reduced using our optional accessory module ZHO.

7.2 Performance optimization

The ratio of the speed between the return stroke and the fast approach stroke must be set in order to ensure optimum performance.

- An optimum speed ratio between fast approach stroke and return stroke.
- A balanced power stroke speed.
- Adequately sized connection sizes (cross-section of hose, switching valves, maintenance unit) that prevent a reduction of the power stroke speed.

For technical data and installation dimensions see data sheet.

(<http://www.tox-pressotechnik.de>)

7.3 Avoidance of dynamic oil leakage

The dynamic oil leakage is based on the physical effect of drag flow: the higher the speed, the thicker the oil film dragged along. In the case of an unfavorable speed ratio between the fast approach stroke and return stroke, an oil film could get into the pneumatic chambers of the Powerpackage.

The following applies:

- The ratio of the speed between the return stroke and the fast approach stroke must be set.
 - For setting the speed ratios, also the exhaust air dampers must be installed on the fast approach stroke connections and the return stroke connections.
- A balanced power stroke speed.
 - For the attuned power stroke speed an exhaust air damper must also be installed in the power stroke venting.
- For the throttled power stroke speed, the speed ratios between power stroke speed and venting of the power stroke must be set.
See Installing the speed reduction for power stroke venting.
- The power cross sections to the Powerpackage (hose cross sections, switching valves, maintenance unit) must at least meet the specifications in the type sheet.

For technical data and installation dimensions see the type sheet.

(<https://tox-pressotechnik.com/>)

7.3.1 Setting speed ratio of return stroke to fast approach stroke

The speed of the working piston in the fast approach stroke and return stroke can be set with external exhaust air dampers on the forward stroke and return stroke. The exhaust air dampers may have to be retrofitted.

Type
line-X
Necessary speed ratio
<ul style="list-style-type: none"> Return stroke equally fast as fast approach stroke or Return stroke faster than the fast approach stroke

Tab. 2 Necessary speed ratio



A visual check of the speeds is generally sufficient.

1. Set speed ratio according to the specifications.
2. Perform test and check the speed visually.

7.3.2 Set the speed ratio between power stroke and power stroke venting (optional)

At throttled power stroke speed
Necessary speed ratio between power stroke and power stroke venting
<ul style="list-style-type: none"> Power stroke speed equal to the return stroke speed of the intensifier piston or Power stroke speed faster than the return stroke speed of the intensifier piston

Tab. 3 Necessary speed ratio



A visual check of the speeds is generally sufficient.

1. Set speed ratio according to the specifications.
2. Perform test and check the speed visually.

7.4 Stroke limitation of the power stroke

For applications for which a fixed end stop is required, the total stroke of the Powerpackage can be limited.

For punch applications a limiting the travel of the power stroke must take place. The travel of the power stroke must be limited to a maximum of 80%.

The travel of the power stroke can be limited by:

- Stroke limitation in the tool.
- Stroke limitation by a set total stroke (fast approach stroke and power stroke).
- Stroke limitation by setting the total stroke length and cutting impact damping (ZSD).

Stroke limitation of the power stroke in the tool

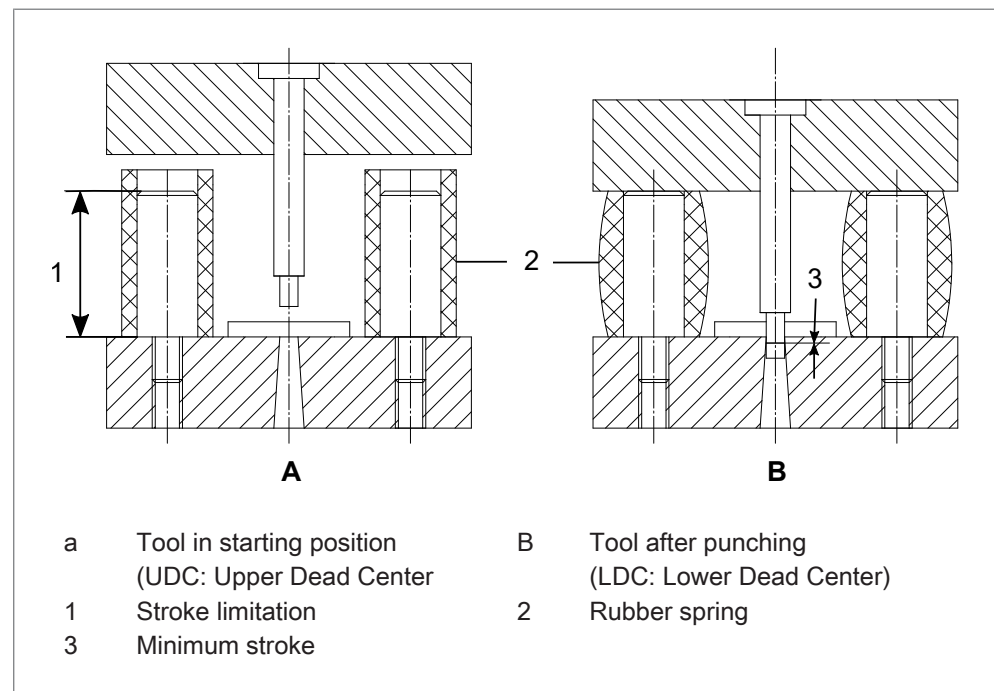

Fig. 8 Stroke limitation in the tool

After the punching process the tool limits the power stroke (LDC).

7.5 Power limit of the power stroke

It is possible to monitor the press force of the power stroke by connecting an oil pressure switch or an oil pressure monitor. Upon reaching the desired press force, the return stroke must be induced.

The press force can be reduced permanently by installing a pressure control in the power stroke line.



An oil pressure of at least 30 bar is necessary for pressure control in the power stroke line (ZDK).

7.6 Speed reduction of the power stroke

The speed of the power stroke can be reduced if a control throttle is installed in the supply line for the power stroke.

To prevent a dynamic oil leakage, an additional exhaust throttle must be installed in this case so that the speed ratio can be adjusted.

See Installing speed reduction for power stroke.

7.7 Changeover of power stroke to return stroke for Powerpackages with hydraulic damping (ZED, ZSD)

For Powerpackages with hydraulic damping (ZED, ZSD) there is an increase in oil pressure in the power stroke. The oil pressure can therefore not be used as signal for the return stroke.

To switch over from power stroke to return stroke, a distance-dependent signal must be selected.

7.8 Horizontal installation Type K and Z

For horizontal installation type K, Z the following applies:

- When the diameter difference between the working part and the intensifier part is large, the weight of the intensifier needs to be supported.
- The intensifier may only rest on the support device and must not be screwed onto the working part.



A horizontal assembly with a standing intensifier facing up or with a hanging intensifier facing down is preferable to a lateral assembly.

7.9 Holding brake (Assembly ZSL)

The following applies for the installation and use of the holding brake (ZSL):

- The holding brake serves exclusively for the mechanical safety of a tool up to the maximum admissible load (see type plate).
- The holding brake is intended for operation in dry, clean production halls (normal factory environment).
In case of strong generation of dirt around the holding brake, e.g. grinding dust, swarf, cooling agent or other liquid media, special protective measures are required.
- During normal operation the holding brake is to be so activated that it opens.
In all other operating conditions, power failure, emergency-stop, etc., the holding fixture activates and holds the piston rod or brakes the load. At a defect of the supply line to the holding fixture the load is secured.
- If the pressure is not sufficiently constant (e.g. "pressure hole" at the start of the lowering movements) a check valve must be installed in the compressed air supply of the valve.
- If impact noises occur during the opening of the holding brake due to the relatively high pressure, they can be suppressed with a throttle in the pressure line (connection 'L').
- The pressure room of the clamping head and its pressure feed line must always be vented.

7.9.1 Electrical activation

The following applies:

- Two signals can be taken by means of proximity switches.
- A safe state exists when signal 'A' (load secured) is active.
This signal must be processed and displayed by the machine control.
- The function must be cyclically monitored, which happens suitably by the cyclical adjustment with signal 'B' (clamping released).
- Downward travel is only possible if signal 'B' is active after pressure is applied to the holding fixture (clamping released).
The control must be programmed in such a way that when this signal is missing, upward travel takes place automatically until signal 'B' (clamping released) appears.

8 Activation and pressure control

8.1 Design principles of activation

A distance-dependent external power stroke switch is recommendable:

- For a piston rod working upwards.
- In the case of a heavy tool weight.
- In the case of fast approach stroke travel that is interrupted on account of the application (e.g. for fixing in place a spring-loaded holding-down clamp).
- If the control throttle 'X' cannot be adjusted for reasons of installation.

An external power stroke release with an electrical release signal is recommendable:

- If the power stroke release can accidentally be activated with the control throttle 'X' due to interference contours in the working area.

The following applies for the activation of the compressed air supply during venting:

- During venting, the return stroke and pressure valve (pneumatic spring) must be impinged with compressed air.
- It must not be possible to activate the fast approach stroke and the power stroke when doing so.
- Attach drop protection if necessary.

When depressurizing a pressure valve (pneumatic spring), the following applies:

- When the forward stroke connection and back stroke connection are switched, the compressed air supply of the pneumatic spring must also be turned off.

8.1.1 Measuring connection and control connection

The oil pressure proportional to the press force is present on the measuring connection and control connection.

This can be displayed, for example, by connecting a pressure gauge or used via transmission to a pressure switch for generating a switching pulse.

The following applies for the activation of the compressed air supply during venting:

- During venting, the return stroke and pressure valve (pneumatic spring) must be impinged with compressed air.
- It must not be possible to activate the fast approach stroke and the power stroke when doing so.
- Attach drop protection if necessary.

When depressurizing a pressure valve (pneumatic spring), the following applies:

- When the forward stroke connection and back stroke connection are switched, the compressed air supply of the pneumatic spring must also be turned off.

8.2 Activation according to dynamic pressure method for Powerpackage

If the working piston meets a counterforce during the fast approach stroke, it stops and the dynamic pressure acting on the piston surface falls. The power stroke valve switches and the intensifier piston is impinged with compressed air.

The changeover time is controlled and adjusted with the control throttle X.

The drive is actuated like a double-acting pneumatic cylinder, via an electrical, pneumatic or mechanical 4/2 or 5/2 directional control valve or via a 4/3 or 5/3 directional control valve.

The drive must be switched to initial position before changing over to the fast approach stroke.

8.2.1 Powerpackage with pressure valve (pneumatic spring)

Powerpackage with pneumatic spring and fast stroke support

Applicable for:

- Powerpackage line-X: Type X-S, X-K

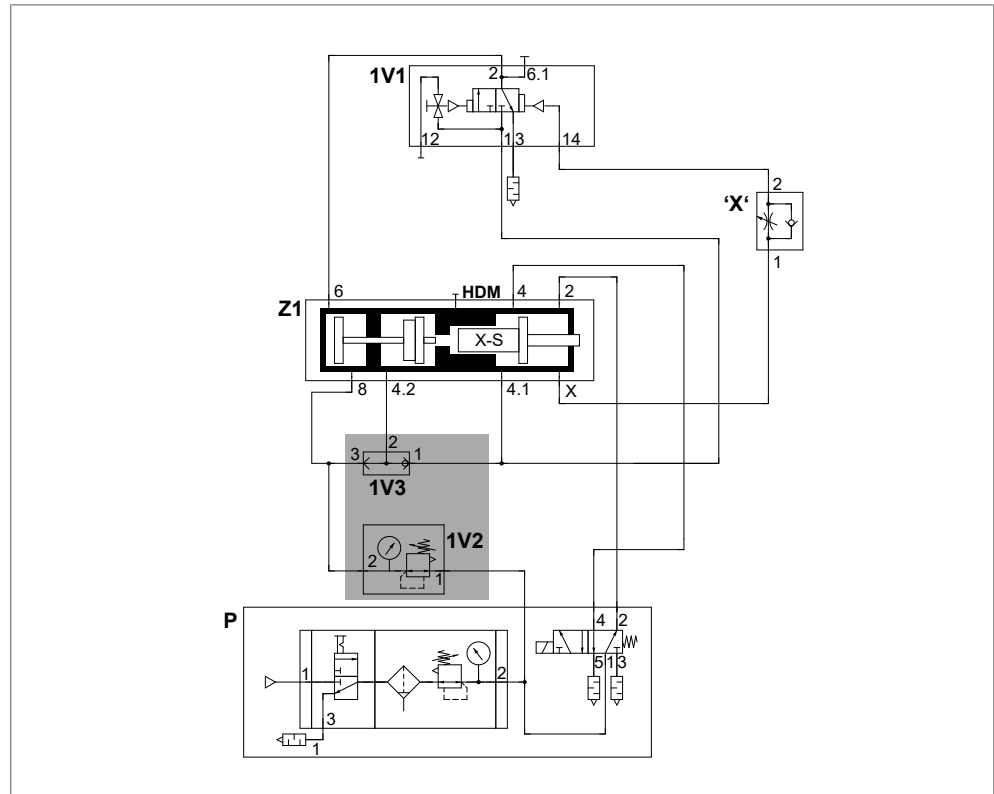

Fig. 9 Activation according to dynamic pressure method with pneumatic spring and fast stroke support

Assembly	
1V1	Power stroke valve
	2 Power stroke output
	6.1 Power stroke signal
	14 Control connection
	3 Muffler output
	1 Power stroke input
	12 Control connection
1V2	Pressure valve (pneumatic spring)
1V3	Fast stroke support
1V4	Pneumatic spring switch-off (type X-K 75/X-K 100 only)
'X'	Control throttle 'X'
Z1	Drive (example type X-S)
	8 Plunger return stroke input
	4.2 Reservoir input
	4.1 Fast approach stroke output
	X Control throttle 'X' output
	2 Return stroke input
	4 Fast approach stroke input
	HPM High pressure measuring connection
	6 Power stroke input
P	To be carried out by the customer: Compressed air supply and maintenance unit (not included in delivery)

Powerpackage with pneumatic spring cut-out in power stroke line (only line-X, X/K-75 and X/K-100)

Applicable for:

- Powerpackage with pneumatic spring cut-out in power stroke line
- Powerpackage line-X: Type X-S, X-K

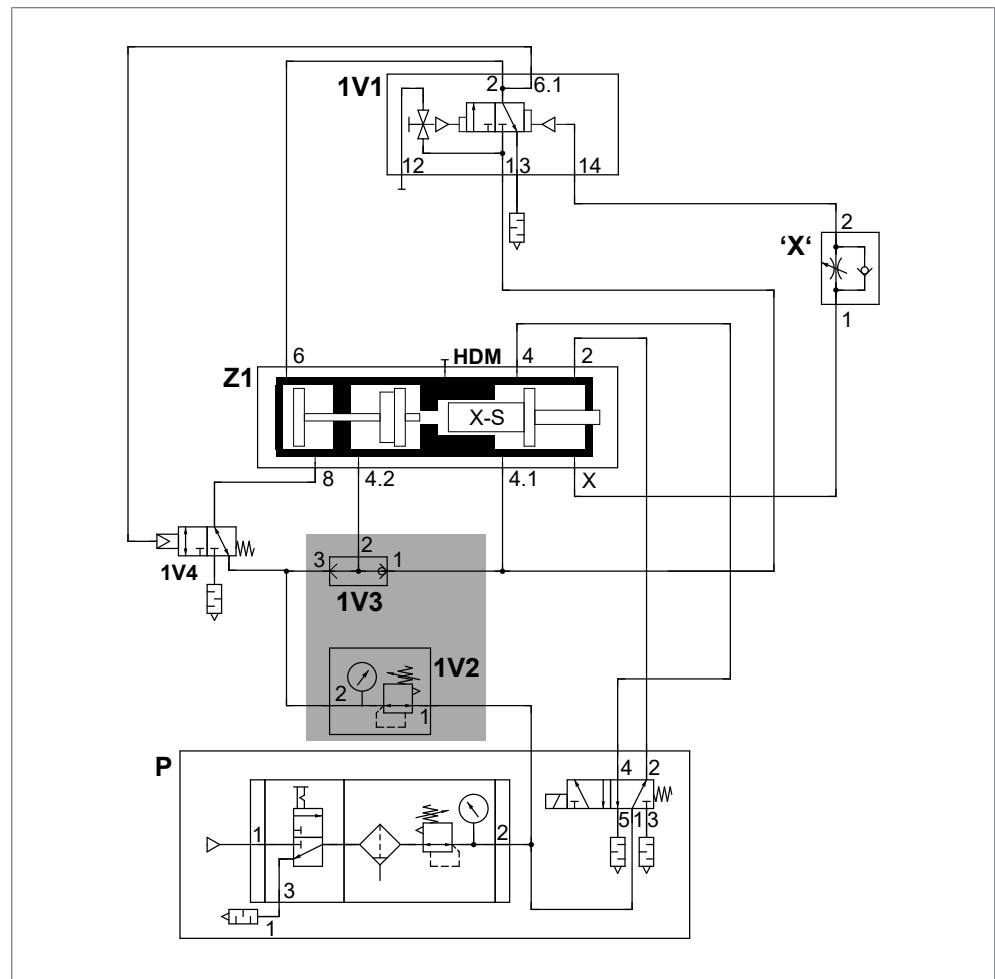

Fig. 10 Activation according to dynamic pressure method with pneumatic spring and fast stroke support and pneumatic spring cut-out in the power stroke line (line-X, X-75 and X-100)

	Assembly	
1V1	Power stroke valve	
	2	Power stroke output
	6.1	Power stroke signal
	14	Control connection
	3	Muffler output
	1	Power stroke input
	12	Control connection
1V2	Pressure valve (pneumatic spring)	
1V3	Fast stroke support	
1V4	Pneumatic spring switch-off (type X-K 75/X-K 100 only)	
'X'	Control throttle 'X'	
Z1	Drive (example type X-S)	
	8	Plunger return stroke input
	4.2	Reservoir input
	4.1	Fast approach stroke output
	X	Control throttle 'X' output
	2	Return stroke input
	4	Fast approach stroke input
	HPM	High pressure measuring connection
	6	Power stroke input
P	To be carried out by the customer: Compressed air supply and maintenance unit (not included in delivery)	



Pneumatic spring switch-off (type X-K 75/X-K 100 only)

For the pneumatic spring switch-off, a valve is mounted between connection [8] of drive connection [3] of the fast stroke support and connection [2] of the fast stroke support. The valve is connected to connection [6.1] of the power stroke valve.

8.3 Pressure control in the power stroke line (assembly ZDK) (optional)

A pressure valve in the power stroke line enables individual adaptation of the press force. No additional rapid vent valve is required. The required size depends on the size of the power stroke valve.

For installing the pressure regulation, see the operating manual, chapter Installation.

8.3.1 Powerpackage with pressure valve (pneumatic spring)

Applicable for:

- Powerpackage line-X: Type X-S, X-K

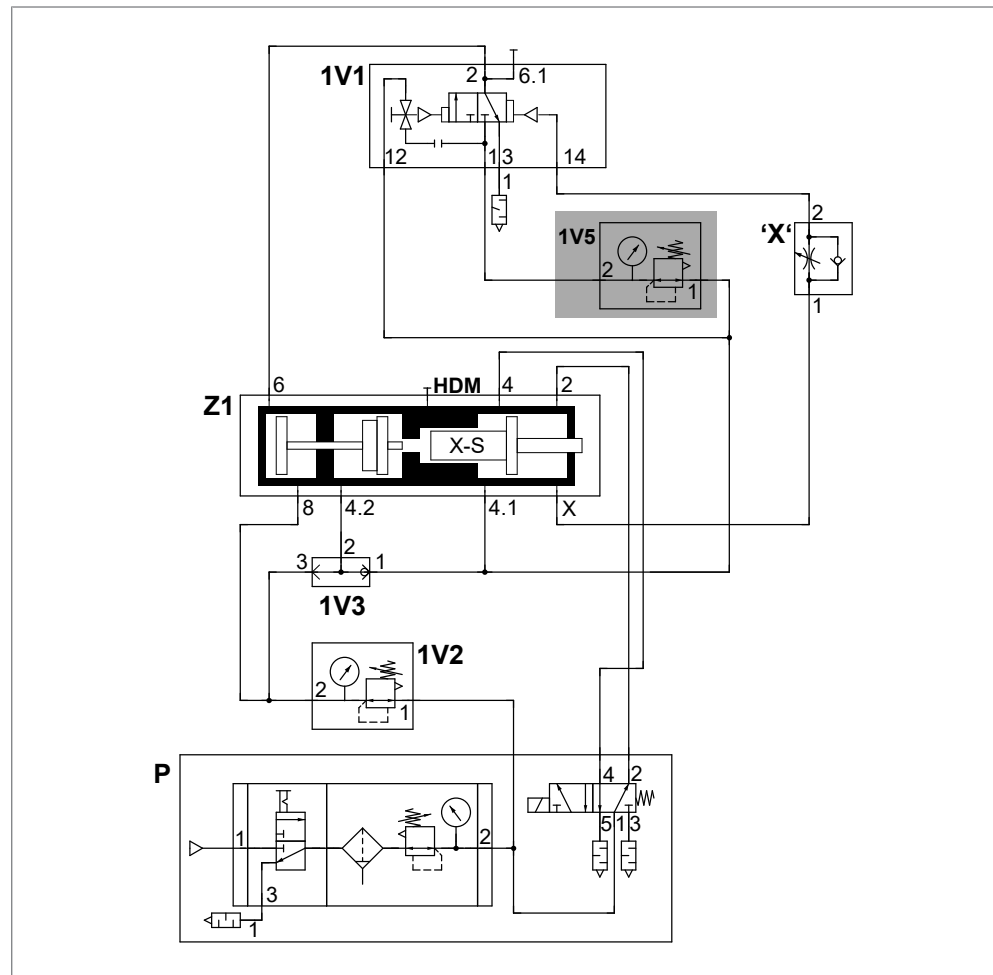

Fig. 11 Pressure control in the power stroke line (assembly ZDK)

	Assembly	
1V1	Power stroke valve	
	2	Power stroke output
	6.1	Power stroke signal
	14	Control connection
	3	Muffler output
	1	Power stroke input
	12	Control connection
1V2	Pressure valve (pneumatic spring)	
1V3	Fast stroke support	
1V5	Pressure regulator ZDK .2	
	1	Fast approach stroke input
	2	Power stroke output
'X'	Control throttle 'X'	
Z1	Drive (example type X-S)	
	8	Plunger return stroke input
	4.2	Reservoir input
	4.1	Fast approach stroke output
	2.1	Return stroke output
	2	Return stroke input
	4	Fast approach stroke input
	HPM	High pressure measuring connection
	6	Power stroke input
P	To be carried out by the customer: Compressed air supply and maintenance unit (not included in delivery)	

8.4 Pressure control in the power stroke line with proportional pressure control valve (optional)

The electrical proportional valve in the power stroke line enables individual adaptation of the press force. No additional rapid vent valve is required. The required size depends on the size of the power stroke valve.

For installing the pressure regulation, see the operating manual, chapter Installation.

8.4.1 Powerpackage with pressure valve (pneumatic spring)

Applicable for:

- Powerpackage line-X: Type X-S, X-K

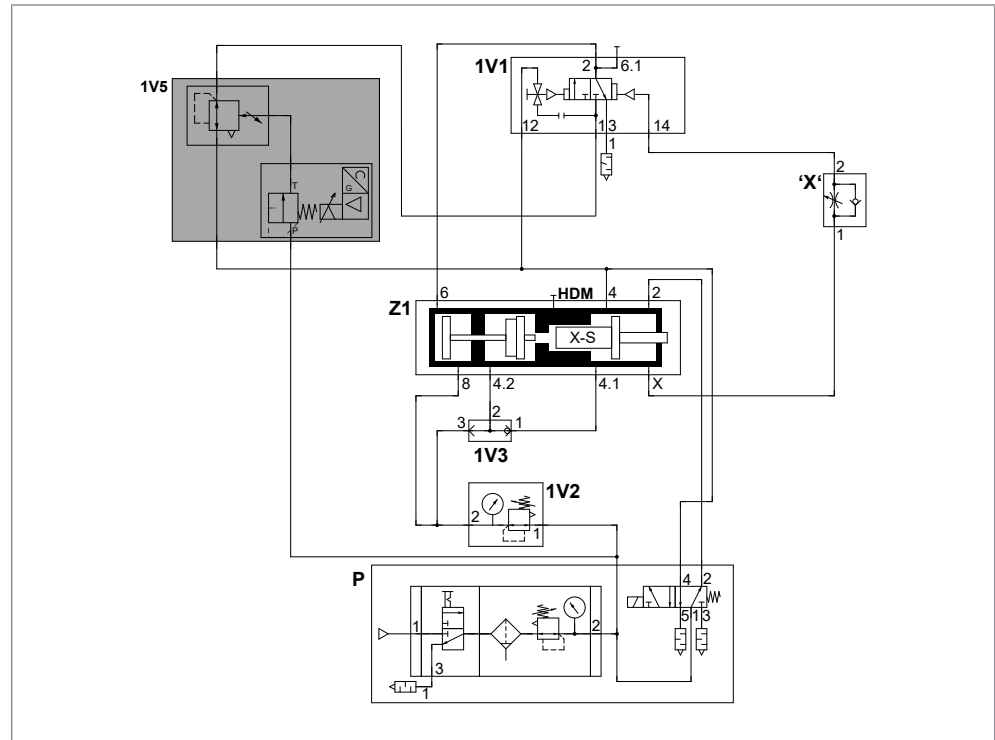

Fig. 12 Pressure control in the power stroke line with proportional pressure control valve

	Assembly	
1V1	Power stroke valve	
	2	Power stroke output
	6.1	Power stroke signal
	14	Control connection
	3	Muffler output
	1	Power stroke input
	12	Control connection
1V2	Pressure valve (pneumatic spring)	
1V3	Fast stroke support	
1V5	Electrical proportional valve	
	1	Fast approach stroke input
	2	Power stroke output
'X'	Control throttle 'X'	
Z1	Drive (example type X-S)	
	8	Plunger return stroke input
	4.2	Reservoir input
	4.1	Fast approach stroke output
	2.1	Return stroke output
	2	Return stroke input
	4	Fast approach stroke input
	HPM	High pressure measuring connection
	6	Power stroke input
P	To be carried out by the customer: Compressed air supply and maintenance unit (not included in delivery)	

8.5 External power stroke switch (assembly ZKHZ) (optional)

In the case of the external power stroke switch, the power stroke is initiated after reaching a particular distance or after a certain period of time.

With the external power stroke switch option, the power stroke valve can be switched using an electrically actuated 3/2-way valve.

An external power stroke switch can also be fitted retrospectively. The control system can be combined with a pressure regulator in the power stroke line.

The following is required:

- Permanent compressed air supply of the electrical 3/2-way valve with 3 to 6 bar (connection G 1/8").
- Electric switching signal (24 V) for switching the power stroke, e.g. a proximity switch ZHS 001 in combination with the stroke monitoring device ZHU, or output signal of a travel transducer ZKW/ZHW.
- Setting the position sensor of the stroke monitoring to the fast approach stroke end position to prevent an overload.

8.5.1 Powerpackage with pressure valve (pneumatic spring)

Applicable for:

- Powerpackage line-X: Type X-S, X-K

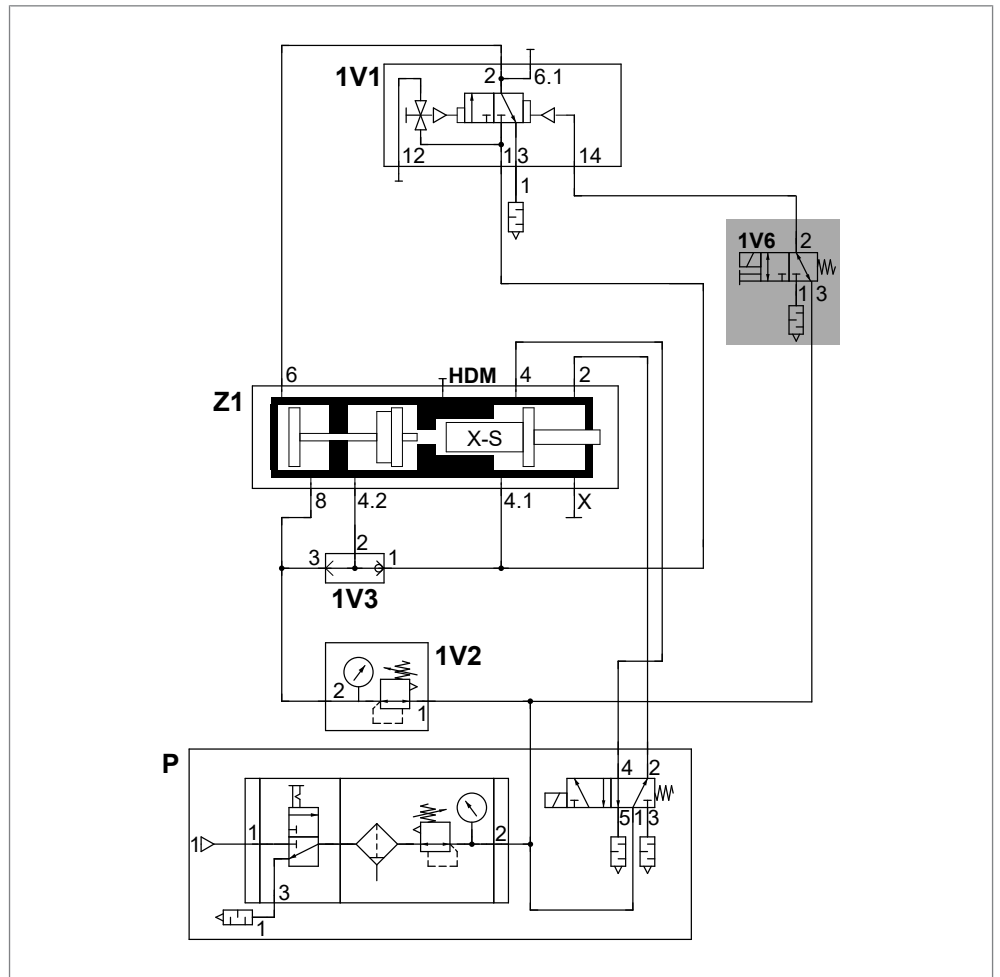

Fig. 13 External power stroke switch (subassembly ZKHZ)

Assembly	
1V1	Power stroke valve
	2 Power stroke output
	6.1 Power stroke signal
	14 Control connection
	3 Muffler output
	1 Power stroke input
	12 Control connection
1V2	Pressure valve (pneumatic spring)
1V3	Fast stroke support
1V6	Power stroke switch valve
	1 Muffler output
	2 Output
	3 Input
Z1	Drive (example type X-S)
	8 Plunger return stroke input
	4.2 Reservoir input
	4.1 Fast approach stroke output
	2.1 Return stroke output
	2 Return stroke input
	4 Fast approach stroke input
	HPM High pressure measuring connection
	6 Power stroke input
P	To be carried out by the customer: Compressed air supply and maintenance unit (not included in delivery)

8.6 External power stroke deactivation (assembly ZKHD) (optional)

The power stroke can be deactivated with an electrical signal if necessary. An external power stroke deactivation can also be fitted retrospectively. The control system can be combined with a pressure regulator in the power stroke line.

The following is required:

- Permanent compressed air supply of the electrical 3/2-way valve with 3 to 6 bar (connection G 1/8").

8.6.1 Powerpackage with pressure valve (pneumatic spring)

Applicable for:

- Powerpackage line-X: Type X-S, X-K

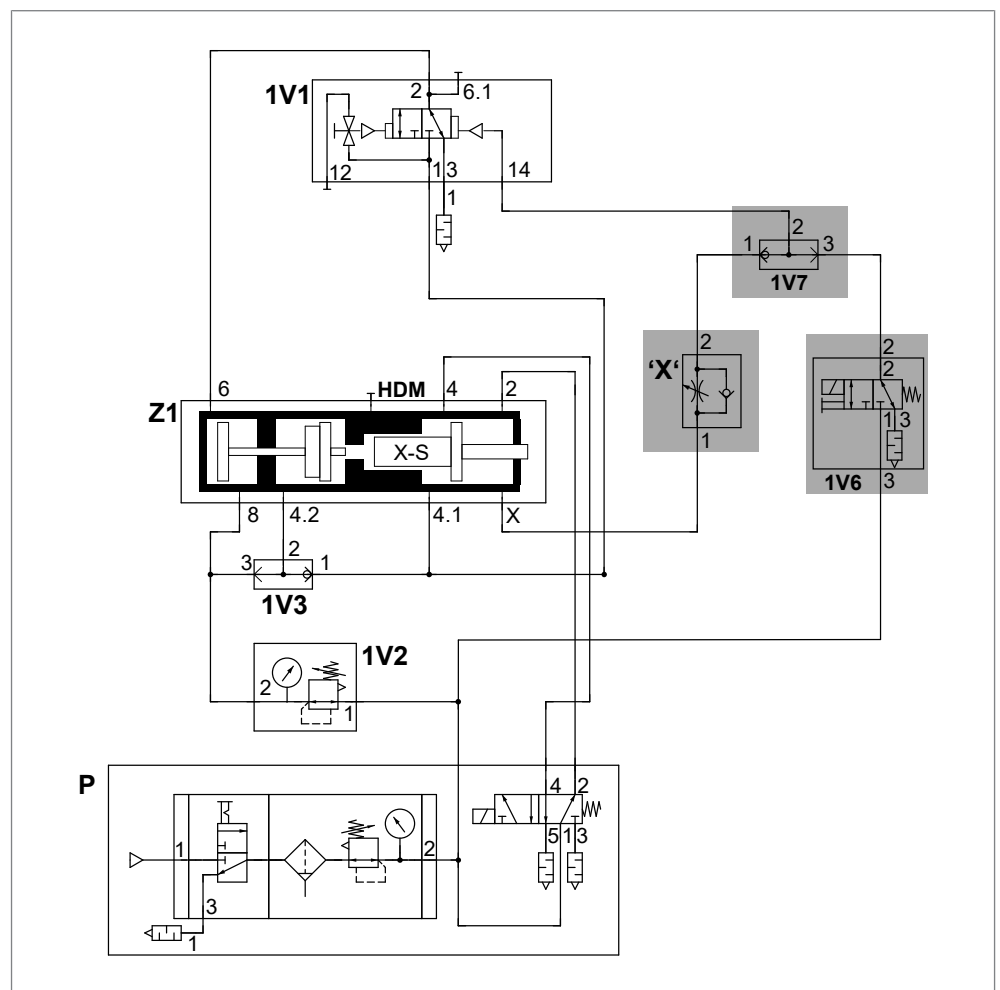

Fig. 14 External power stroke deactivation (assembly ZKHD)

Assembly	
1V1	Power stroke valve
	2 Power stroke output
	6.1 Power stroke signal
	14 Control connection
	3 Muffler output
	1 Power stroke input
	12 Control connection
1V2	Pressure valve (pneumatic spring)
1V3	Fast stroke support
1V6	Electrical switching valve
	3 Input (release)
	2 Output
	1 Input (deactivation)
1V7	OR valve
	3 Switching valve input
	1 Control throttle 'X' input
	2 Output
'X'	Control throttle 'X'
Z1	Drive (example type X-S)
	8 Plunger return stroke input
	4.2 Reservoir input
	4.1 Fast approach stroke output
	2.1 Return stroke output
	2 Return stroke input
	4 Fast approach stroke input
	HPM High pressure measuring connection
	6 Power stroke input
P	To be carried out by the customer: Compressed air supply and maintenance unit (not included in delivery)

8.7 External power stroke release (assembly ZKHF) (optional)

The power stroke can be released with an electrical signal if necessary. An external power stroke deactivation can also be fitted retrospectively. The control system can be combined with a pressure regulator in the power stroke line.

The following is required:

- Permanent compressed air supply of the electrical 3/2-way valve with 3 to 6 bar (connection G 1/8").

8.7.1 Powerpackage with pressure valve (pneumatic spring)

Applicable for:

- Powerpackage line-X: Type X-S, X-K

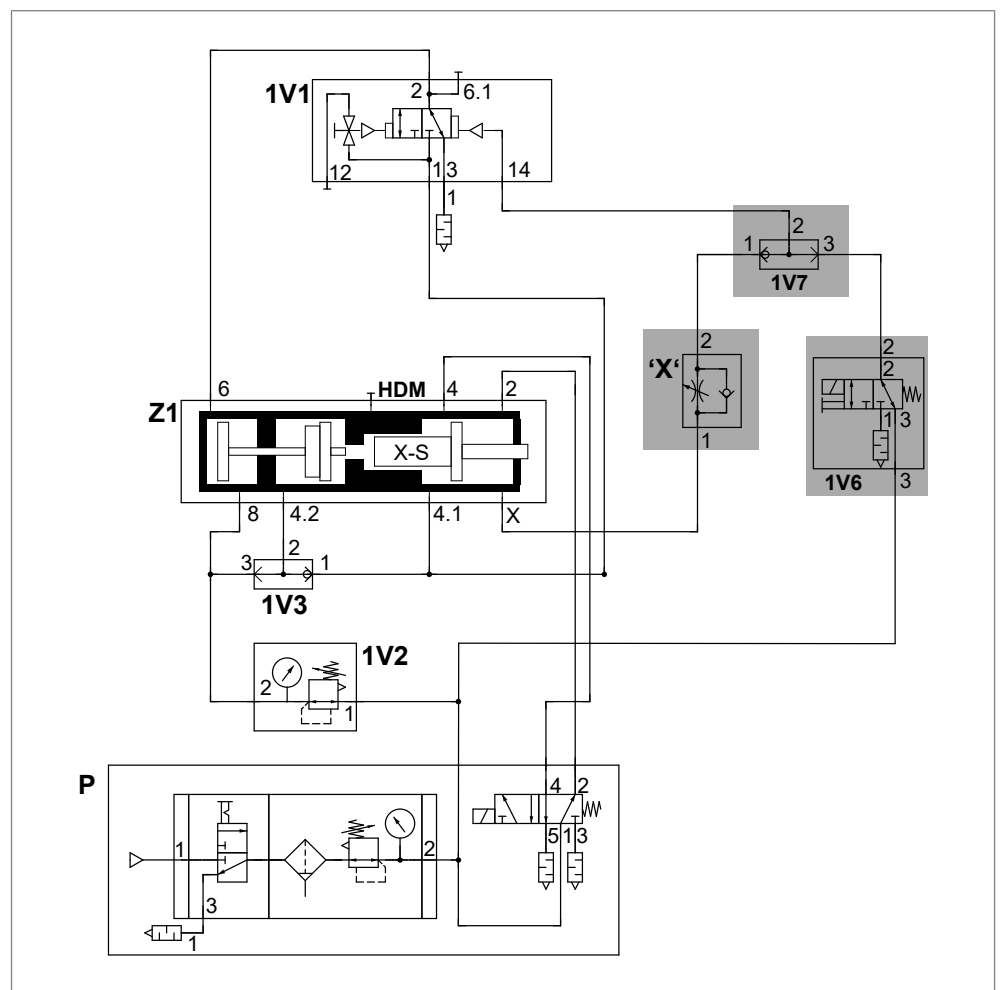

Fig. 15 External power stroke release (assembly ZKHF)

Assembly	
1V1	Power stroke valve
	2 Power stroke output
	6.1 Power stroke signal
	14 Control connection
	3 Muffler output
	1 Power stroke input
	12 Control connection
1V2	Pressure valve (pneumatic spring)
1V3	Fast stroke support
1V6	Electrical switching valve
	3 Input (release)
	2 Output
	1 Input (deactivation)
1V7	OR valve
	3 Switching valve input
	1 Control throttle 'X' input
	2 Output
'X'	Control throttle 'X'
Z1	Drive (example type X-S)
	8 Plunger return stroke input
	4.2 Reservoir input
	4.1 Fast approach stroke output
	2.1 Return stroke output
	2 Return stroke input
	4 Fast approach stroke input
	HPM High pressure measuring connection
	6 Power stroke input
P	To be carried out by the customer: Compressed air supply and maintenance unit (not included in delivery)

8.8 External power stroke supply (optional)

In the case of the external power supply, the power stroke valve is supplied with compressed air separately and independently from the fast approach stroke. The power stroke can be released by a dynamic pressure switch, an external power stroke switch (assembly ZKZ), or by an external power stroke release (ZKHZ).

If a power stroke deactivation (assembly ZKHD) is installed, the power stroke can be deactivated with an electrical signal if necessary.

The control system can be combined with a dynamic pressure switch, an external power stroke switch, an external power stroke release or a power stroke deactivation.

The following is required:

- External pressure supply at connection [1] of the power stroke valve.

8.8.1 Powerpackage with pressure valve (pneumatic spring)

Applicable for:

- Powerpackage line-X: Type X-S, X-K

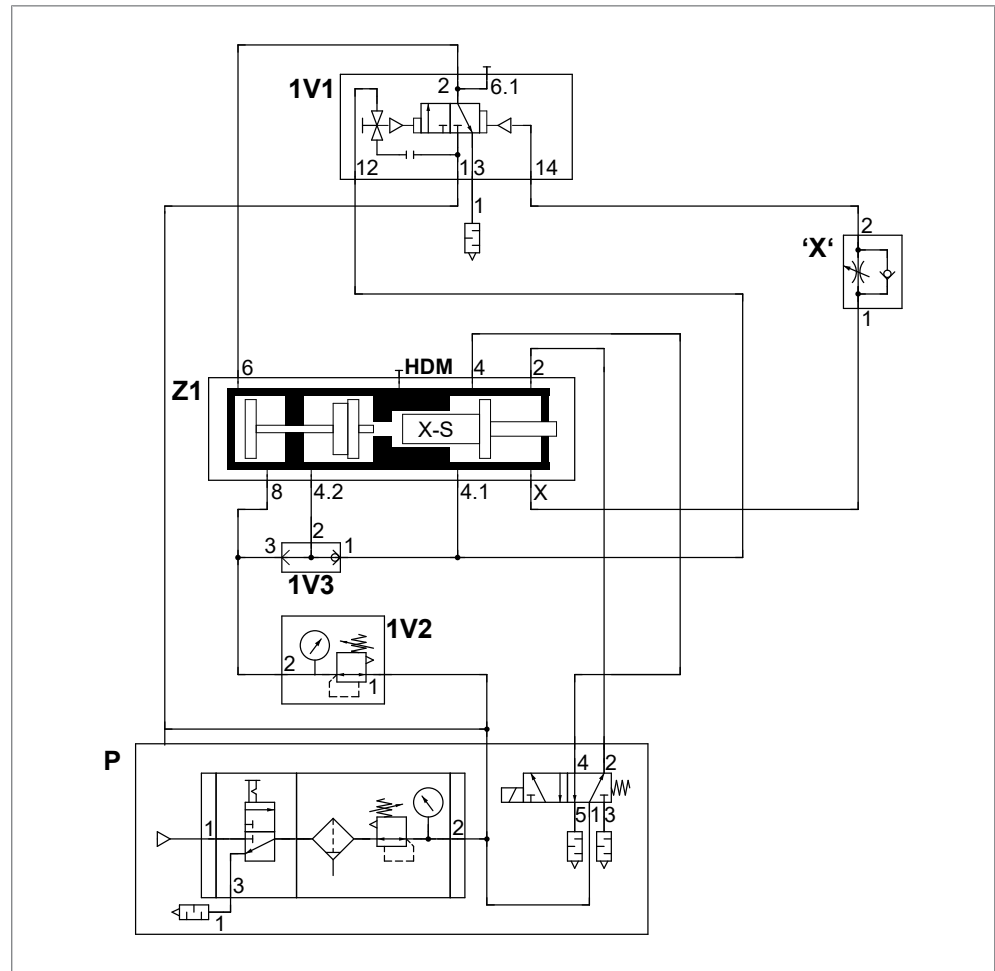

Fig. 16 External power stroke supply (optional)

	Assembly	
1V1	Power stroke valve	
	2	Power stroke output
	6.1	Power stroke signal
	14	Control connection
	3	Muffler output
	1	Power stroke input
	12	Control connection
1V2	Pressure valve (pneumatic spring)	
'X'	Control throttle 'X'	
Z1	Drive (example type X-S)	
	8	Plunger return stroke input
	4.2	Reservoir input
	4.1	Fast approach stroke output
	2.1	Return stroke output
	2	Return stroke input
	4	Fast approach stroke input
	HPM	High pressure measuring connection
	6	Power stroke input
P	To be carried out by the customer: Compressed air supply and maintenance unit (not included in delivery)	

8.9 Adjustable damping (assembly ZED) (optional)

Applicable for:

- Powerpackage line-X: Type X-S, X-K
- Powerpackage: Type EL, EK

The integrated damping option allows an adjustable constant speed of the working piston during the approach stroke and power stroke, independent of the working forces.

Thus, the following can be compensated:

- When joining: stick-slip effect.
- When stamping: sudden acceleration of the working piston when the opposing force, the stamping impact, is removed.

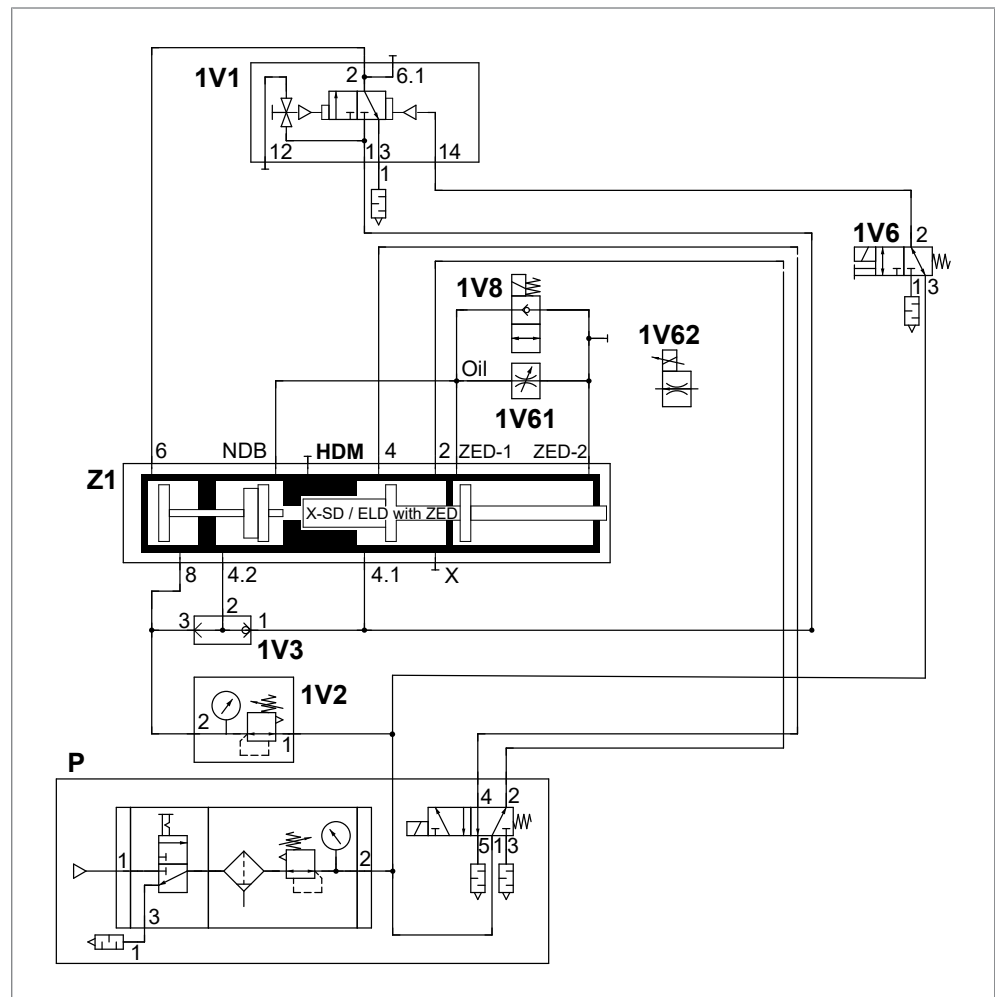

Fig. 17 Adjustable damping ZED (optional)

	Assembly
1V1	Power stroke valve
1V2	Pressure valve (pneumatic spring)
1V3	Fast stroke support
1V6	Power stroke valve
1V61	Manual flow control valve
1V62	Electric proportional flow control valve (optional)
1V8	Damping On / Off
Z1	Drive
P	To be carried out by the customer: Compressed air supply and maintenance unit (not included in delivery)

Index

A

Activation	
Design principles	35
Dynamic pressure method	37
Electric	34
Adjustable damping	56
Air consumption	28
Air pressure	
Type X-S, Type X-K	21
Avoidance of dynamic oil leakage	30

C

Changeover from power stroke to return stroke	
For Powerpackages with hydraulic damping	
.....	33
Changeover of power stroke to return stroke	
ZED	33
ZSD	33
Compressed air quality	21
Contact	9
Control connection	36
Cycle times	29

D

Data sheet	25
Design data	25
Design principles	27
Design principles of activation	35
Document	
Validity	8
Documents	
other applicable	8
Dynamic oil leakage	
Avoiding	30
Dynamic pressure method	
Activation	37

E

Electrical activation	34
Equipment	
Optional	13, 15
Exclusion of liability	7
External power stroke connection	46
External power stroke deactivation	49
External power stroke release	51
External power stroke supply	53

F

Fast approach stroke	18
Function description	17

G

Gender note	8
-------------------	---

H

Horizontal installation	
Type K, Z	33
Hydraulic damping	
Changeover from power stroke to return	
stroke	33
Hydraulic oil	
Specification	23

I

Important information	7
information	
Important	7
Installation	
Tightening torques	22
Integrated damping function	
Product overview	13
Integrated holding brake	
Product overview	14

L

Legal note	7
line-X	
Product overview	11

M	
Measuring connection	36
N	
Note	
Gender	8
Legal	7
O	
Oil leakage	
Avoiding	30
Oil pressure	
Type X-S, Type X-K.....	21
Optional	
Equipment.....	13
P	
Piston rod	
Tightening torques	22
Pneumatic connection	21
Power limit	
Power stroke	33
Power stroke	19
Power limit	33
Speed reduction.....	33
Stroke limitation	32
Power stroke supply, external	53
Press force table	22
Pressure control in the power stroke line with	
Proportional pressure control valve	44
Pressure regulation in power stroke line	42
Product overview	
Integrated damping function	13
Integrated holding brake	14
line-X.....	11
Proportional pressure control valve	
Pressure control in the power stroke line..	44
R	
Return stroke	20
S	
Set	
Speed ratio between power stroke and	
power stroke venting	31
Setting	
Speed ratio between return stroke and fast	
approach stroke	31
Source of supply.....	9
Specification for hydraulic oil.....	23
Speed ratio between power stroke and power	
stroke venting	
Set	31
Speed ratio between return stroke and fast ap-	
proach stroke	
Setting.....	31
Speed reduction	
Power stroke	33
Stroke limitation	
Power stroke	32
T	
Target group	8
Technical data	21
Technical design data	25
Tightening torques	
Installation.....	22
Piston rod.....	22
Type K, Z	
Horizontal installation.....	33
Type X-S, Type X-K	
Air pressure	21
V	
Validity	
Document	8

Z

ZDK

Pressure regulation in power stroke line... 42

ZED

Adjustable damping 56

ZKHD

External power stroke deactivation 49

ZKHF

External power stroke release 51

ZKHZ

External power stroke connection..... 46

